

1. Report No. SWUTC/95/60032-1	2. Government Accession No.	3. Recipient's Catalog No.	
4. Title and Subtitle Prediction of Mobile Source Emissions and Fuel Consumption Using the TEXAS Model		5. Report Date June 1995	
		6. Performing Organization Code	
7. Author(s) Tsai-Yun Liao and Randy B. Machemehl		8. Performing Organization Report No. Research Report 60032-1	
9. Performing Organization Name and Address Center for Transportation Research University of Texas at Austin 3208 Red River, Suite 200 Austin, Texas 78705-2650		10. Work Unit No. (TRAIS)	
		11. Contract or Grant No. 0079	
12. Sponsoring Agency Name and Address Southwest Region University Transportation Center Texas Transportation Institute The Texas A&M University System College Station, Texas 77843-3135		13. Type of Report and Period Covered	
		14. Sponsoring Agency Code	
15. Supplementary Notes Supported by a grant from the Office of the Governor of the State of Texas, Energy Office			
16. Abstract <p>EMPRO is the emissions processor of the TEXAS traffic simulation model and was developed for predicting mobile source emissions and fuel consumption at intersections. Due to changes in federal emissions and fuel consumption standards since the 1981 EMPRO development, updating of vehicle characteristics was badly needed.</p> <p>This report describes the method for developing the EMPRO processor, the procedure for revising vehicle emissions and fuel consumption models, and the model prediction capability.</p>			
17. Key Words Fuel Consumption, Emissions, EMPRO, Emissions Processor, TEXAS Model		18. Distribution Statement No Restrictions. This document is available to the public through NTIS: National Technical Information Service 5285 Port Royal Road Springfield, Virginia 22161	
19. Security Classif.(of this report) Unclassified	20. Security Classif.(of this page) Unclassified	21. No. of Pages 49	22. Price

**PREDICTION OF MOBILE SOURCE
EMISSIONS AND FUEL CONSUMPTION
USING THE TEXAS MODEL**

by

Tsai-Yun Liao
Randy Machemehl

Research Report SWUTC 95/60032

Southwest Region University Transportation Center
Center for Transportation Research
The University of Texas
Austin, Texas 78712

June 1995

EXECUTIVE SUMMARY

Prediction of mobile source emissions and fuel consumption is difficult and costly. However, since mobile source emissions produce one third of the air pollution in the United States, it is necessary to develop appropriate evaluation methods. In 1983, an emissions processor called EMPRO was developed to predict instantaneous vehicle emissions and fuel consumption associated with intersections. EMPRO is an emissions and fuel consumption processor of the TEXAS (Traffic EXperimental and Analytical Simulation Model) model. It utilizes the instantaneous speed and acceleration of each vehicle to compute instantaneous vehicle emissions and fuel consumption along the vehicle path.

In EMPRO, the emissions and fuel consumption models for light-duty vehicles are expressed as functions of vehicle speed and acceleration, but the models for heavy-duty vehicles are expressed as functions of engine torque and engine speed. A "Motion Equation" (Wu, 1980) is derived to relate vehicle speed and acceleration to engine torque and engine speed (RPM). These in turn are used as inputs to a set of regression equations, which are developed to estimate hydrocarbons (HC), carbon monoxide (CO), oxides of nitrogen (NO_x), and fuel consumption rates. Thus, given vehicle speed, acceleration, and vehicle types, the EMPRO can estimate instantaneous vehicle emissions and fuel consumption.

The original models were based upon 1975 vehicle emissions rates; however, due to successively more strict federal controls, vehicular emissions rates have been reduced since 1975. An approach for updating the mobile source emissions and fuel consumption models is presented along with the updated modeling procedures.

ACKNOWLEDGEMENTS

This publication was developed as part of the University Transportation Centers' Program, which is funded 50% in oil overcharge funds from the Stripper Well settlement as provided by the Texas State Energy Conservation Office and approved by the U.S. Department of Energy. Mention of trade names or commercial products does not constitute endorsement or recommendation for use.

ABSTRACT

EMPRO is the emissions processor of the TEXAS traffic simulation model and was developed for predicting mobile source emissions and fuel consumption at intersections. Due to changes in federal emissions and fuel consumption standards since the 1981 EMPRO development, updating of vehicle characteristics was badly needed. This report describes the method for developing the EMPRO processor, the procedure for revising vehicle emissions and fuel consumption models, and the model prediction capability.

TABLE OF CONTENTS

CHAPTER 1 INTRODUCTION	1
Problem Statement	1
Background and Significance of Study	1
CHAPTER 2 TEXAS MODEL	3
Structure of the TEXAS Model	3
The TEXAS Model for Intersection Traffic	5
Emissions Processor for the TEXAS Model (EMPRO)	5
CHAPTER 3 EMPRO EMISSIONS AND FUEL CONSUMPTION MODELS	7
Methodology of the EMPRO Model	7
Emissions and Fuel Consumption Models for Passenger Cars	7
Emissions Models for Passenger Cars	7
Fuel Consumption Model for Passenger Cars	8
Truck Emissions and Fuel Consumption Models	8
Truck Emissions Models	9
Truck Fuel Consumption Models	9
Sensitivity Analysis of the TEXAS Model Emissions Processor	9
CHAPTER 4 MODIFICATION OF THE TEXAS MODEL EMISSIONS PROCESSOR	17
Modification Approach for Vehicle Emissions and Fuel Consumption Models	17
Federal Emissions Regulations and Fuel Economy Standards	18
Vehicle Age Distribution	18
Development of Adjustment Factors for Emissions and Fuel Consumption	21
Emissions Adjustment Factors for Passenger Cars	21
Fuel Consumption Adjustment Factors for Passenger Cars	24
Emissions Adjustment Factors for Trucks	25
Fuel Consumption Adjustment Factors for Trucks	27

Summary	27
CHAPTER 5 CONCLUSIONS AND RECOMMENDATIONS	29
REFERENCES	31
APPENDIX A DOCUMENTATION OF THE TEXAS MODEL EMISSIONS PROCESSOR (EMPRO)	33
APPENDIX B EMPRO, EMISSIONS PROCESSOR, OUTPUT	38

FIGURES

Figure 2.1	Flow Process Of The TEXAS Model With Emissions Processor	4
Figure 3.1	CO Emissions Rates for Vehicle Class 1 to 4	11
Figure 3.2	CO Emissions Rates for Vehicle Class 5	12
Figure 3.3	CO Emissions Rates for Vehicle Class 6	12
Figure 3.4	CO Emissions Rates for Vehicle Class 7	13
Figure 3.5	CO Emissions Rates for Vehicle Class 8	13
Figure 3.6	CO Emissions Rates for Vehicle Class 9	14
Figure 3.7	CO Emissions Rates for Vehicle Class 10	14
Figure 3.8	CO Emissions Rates for Vehicle Class 11	15
Figure 3.9	CO Emissions Rates for Vehicle Class 12	15

TABLES

TABLE 3.1	COEFFICIENTS OF EMISSIONS MODELS FOR PASSENGER CARS IN 1975 [LEE, 1983]	8
TABLE 3.2	VEHICLE CLASS DATA	10
TABLE 4.1	FEDERAL EMISSIONS CONTROL REQUIREMENTS	19
TABLE 4.2	CORPORATE AVERAGE FUEL ECONOMY (CAFE) STANDARDS	19
TABLE 4.3	PASSENGER CARS IN USE BY AGE (AS OF JULY 1)	20
TABLE 4.4	TRUCKS IN USE BY AGE (AS OF JULY 1)	21
TABLE 4.5	WEIGHTED EMISSIONS CONTROL REQUIREMENT FOR PASSENGER CARS IN 1975	22
TABLE 4.6	WEIGHTED EMISSIONS CONTROL REQUIREMENT FOR PASSENGER CARS IN 1990	23
TABLE 4.7	EMISSIONS ADJUSTMENT FACTORS FOR PASSENGER CARS	23
TABLE 4.8	WEIGHTED FUEL ECONOMY STANDARDS FOR PASSENGER CARS IN 1975	24
TABLE 4.9	WEIGHTED FUEL ECONOMY STANDARDS FOR PASSENGER CARS IN 1990	25
TABLE 4.10	FUEL CONSUMPTION ADJUSTMENT FACTORS FOR PASSENGER CARS	25
TABLE 4.11	EMISSIONS ADJUSTMENT FACTORS FOR HEAVY-DUTY GASOLINE TRUCKS	26
TABLE 4.12	EMISSIONS ADJUSTMENT FACTORS FOR HEAVY-DUTY DIESEL TRUCKS	26
TABLE 4.10	FUEL CONSUMPTION ADJUSTMENT FACTORS FOR TRUCKS	27

CHAPTER 1 INTRODUCTION

Problem Statement

The new 1990 Clean Air Act Amendments specify requirements for reduction of air pollution levels caused by a variety of sources which include mobile source emissions. Meeting these requirements will require a variety of actions but in many areas, reduction of mobile source emissions from automobiles will become vital. Updated and enhanced methods for predicting quantities of automobile emissions will soon be needed. Auto emissions prediction methods must be sensitive to vehicular travel speeds, numbers of stops, idling times and other performance measures because these are related to emissions and fuel consumption and are typically effected by street system improvement. Such an emissions prediction method could be used to develop implementation priorities for street and highway improvements in terms of emissions and fuel consumption benefits.

Background and Significance of Study

Prediction of mobile source emissions at intersections is a serious and challenging problem. Vehicle emissions at intersections are usually higher than other street segments because intersections cause vehicles to slow, stop, and accelerate. Pollutants emitted from vehicles near intersections can accumulate at certain points, and these concentrations are very dangerous to human health. Therefore, it is necessary to predict in quantitative terms intersection mobile source emissions.

There are available methods to predict mobile source emissions at intersections [Sculley, 1989]. The U. S. Environmental Protection Agency (EPA) and the Federal Highway Administration (FHWA) have developed various vehicle emissions modeling procedures. The EPA developed two distinct kinds of vehicle emissions rate models [Sculley, 1989]. These models use data from dynamometer tests of vehicles operating under standardized driving cycles.

Other vehicle emissions models, such as TEXIN2, IMM, CALINE4, MICRO2, and EMPRO of the TEXAS model, have been developed in the last decade. The models are based on EPA models and differ in their analysis of vehicle emissions rates and in the prediction procedures. Moreover, the models describe different vehicle emissions characteristics on different

intersection conditions, such as T-intersections, one-way streets, four-way stops, and yield-signs.

It is important to select an appropriate model to predict intersection vehicle emissions. The first task is to develop an understanding of prediction models for intersection vehicle emissions.

The purpose of this report, therefore, is to introduce the EMPRO model and describe the mobile source emissions and fuel consumption prediction approach. The first section of this report introduces the background and significance of the prediction of mobile source emissions and fuel consumption. The next section describes the functions and capabilities of the TEXAS model and the EMPRO processor of the TEXAS model. The third section defines the emissions and fuel consumption models for different vehicles. The fourth section describes the approach for predicting future year mobile source emissions and fuel consumption. The report concludes with a discussion of the feasibility of the modeling procedure and EMPRO results.

CHAPTER 2 TEXAS MODEL

Structure of the TEXAS Model

The TEXAS model is a deterministic microscopic traffic simulation package. It consists of a geometry processor, GEOPRO, a driver-vehicle processor, DVPRO, a traffic simulation processor, SIMPRO, and an emissions processor, EMPRO (see Figure 2-1). GEOPRO defines intersection geometry information from user specifications including all vehicle paths along the approaches and within the intersection. DVPRO uses assigned characteristics of driver classes, vehicle classes, desired speed, desired outbound intersection leg, and lateral lane position on the inbound leg to generate attributes for each individual driver-vehicle unit. SIMPRO integrates all the defined elements and computes deterministically the response of each driver-vehicle unit and simulates the traffic behavior of each unit according to momentary surrounding conditions. EMPRO uses instantaneous vehicle speed and acceleration (deceleration) from SIMPRO to compute instantaneous vehicle emissions and fuel consumption [Lee, 1983].

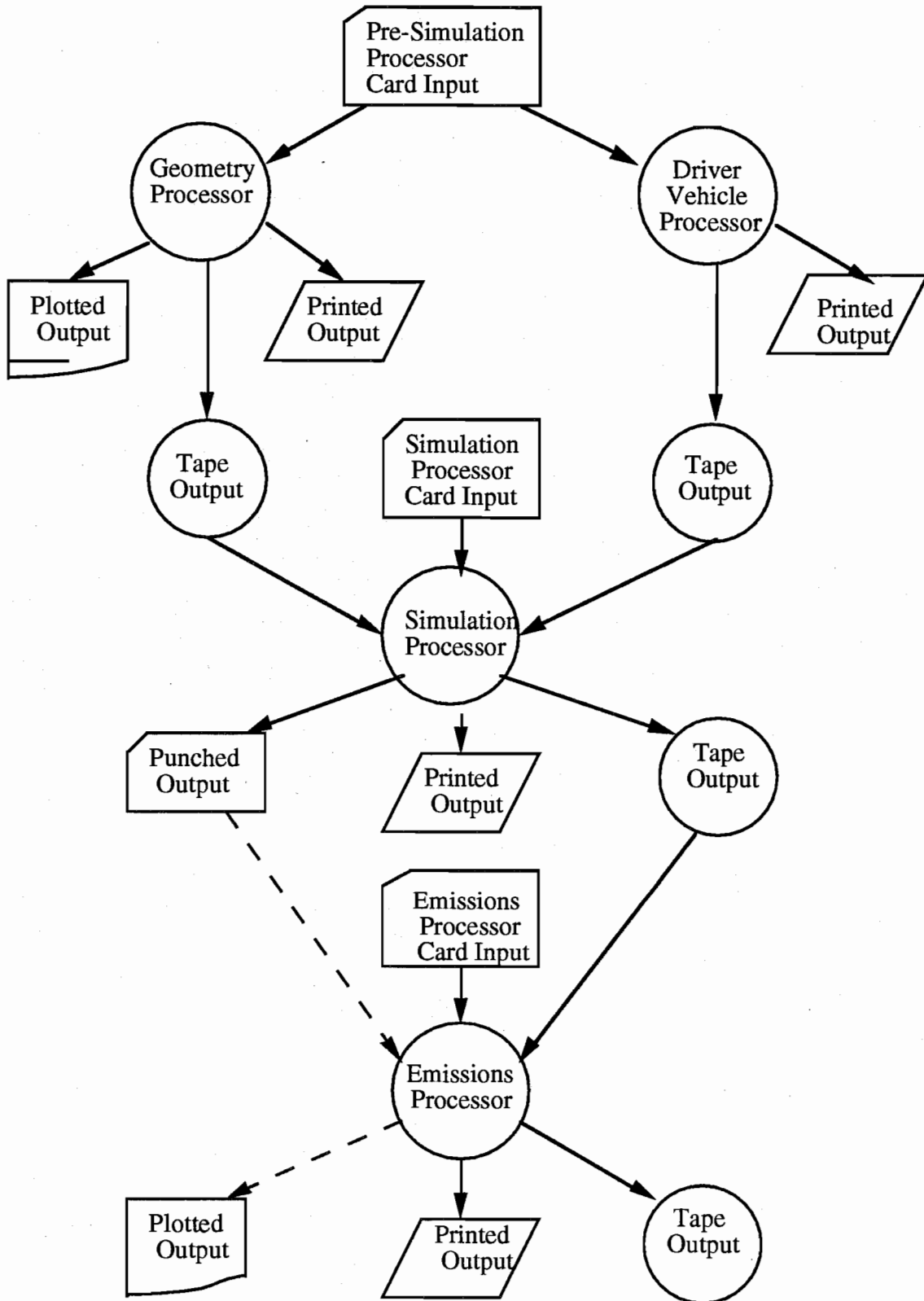

Figure 2-1. Flow Process of the TEXAS Model with Emissions Processor

The TEXAS Model for Intersection Traffic

TEXAS is a microscopic deterministic simulation model which processes each individual driver-vehicle unit through a defined intersection. It simulates the position, speed and acceleration for each driver-vehicle unit during each simulation time increment (either 1.0 or 0.5 seconds). When each individual vehicle enters its respective inbound approach, its entry speed is set so that it will follow the unit immediately ahead of it and will not exceed a selected desired speed. Each unit attempts to travel at its desired speed but accelerates and decelerates or changes lanes in response to other units. If there is no leading unit on the inbound approach, the unit enters with its desired speed and responds to traffic control requirements. Thus all driver-vehicle units have instantaneous trajectory information developed for them by the simulation processor.

Although the TEXAS model limits driver-vehicle unit definitions to 3 combinations of driver classes and 12 vehicle classes, it can simulate vehicle behavior at a single, multi-leg, multi-lane, mixed-traffic intersection. It can simulate seven types of intersection traffic control: (1) pretimed signals, (2) full-actuated signals, (3) semi-actuated signals, (4) all-way stop signs, (5) stop signs only on minor, (6) yield signs only on minor streets, and (7) no control. It uses stochastic processes creating traffic streams composed of mixed driver and vehicle classes, headways, desired speeds, and other characteristics prior to simulation. For example, users can choose from six distribution functions to compute initial time headways including: (1) negative exponential, (2) shifted negative exponential, (3) uniform, (4) lognormal, (5) gamma, and (6) Erlang. Users specify the start-up time, simulation time, and simulation time increment.

Emissions Processor for the TEXAS Model (EMPRO)

EMPRO uses instantaneous speed and acceleration (deceleration) information from SIMPRO for each vehicle to compute instantaneous vehicle emissions and fuel consumption [Lee, 1983]. Each lane on each approach to an intersection is partitioned into a series of 50 foot sections, and emissions and fuel flow are accumulated on a section basis to show the spatial variation of emissions and fuel consumption with respect to time. The intersection proper is treated as one section, but it contains emissions and fuel consumption values generated by vehicles crossing from all approaches. The length of section on

each inbound lane or outbound lane can be specified by the user as EMPRO input data.

EMPRO produces estimates of CO, HC, CO₂, and NO_x emitted by cars and estimates CO, HC, NO_x emitted by trucks plus fuel consumption for cars and trucks.

CHAPTER 3 EMPRO EMISSIONS AND FUEL CONSUMPTION MODELS

Methodology of the EMPRO Model

EMPRO uses the Modal Analysis Model to formulate the emissions and fuel consumption equations. The Modal Analysis Model is a regression model where emissions (fuel consumption) is the dependent variable and instantaneous speed and acceleration (deceleration) are independent variables. Since the speed, acceleration, and deceleration of trucks are related to engine characteristics, the emissions and fuel consumption models for heavy-duty vehicles are expressed as functions of engine torque and engine speed. An equation called the "Motion Equation" [Wu, 1980] is derived to relate vehicle speed and acceleration to truck engine torque and speed (RPM).

Emissions and Fuel Consumption Models for Passenger Cars

Emissions Models for Passenger Cars

Passenger car types include sports, compact, medium, and large cars. Emissions models for passenger cars developed by the Modal Analysis Model are presented as a nonlinear expression of speed when vehicular speed is steady state, and as a nonlinear function of speed and acceleration when vehicular speed is in a transient state. The emissions models are formulated as follows:

Steady State Model:

$$L(V) = S_1 + S_2V + S_3 V^2$$

L = instantaneous Emissions rate (gram/sec)

V = speed (mph)

S_i = coefficients (listed in Table 3-1), $i = 1, 2, 3$.

Transient State Model:

$$L(V,A) = B_1 + B_2V + B_3A + B_4VA + B_5V^2 + B_6A^2 + B_7V^2A + B_8VA + B_9V^2A^2$$

A = acceleration or deceleration (mph/sec)

B_j = coefficients (list in Table 3-1), $j = 1, \dots, 9$.

Since the models were developed for emissions estimates of 1975 year model vehicles, the estimates must be updated to predict emissions of newer vehicles. The related adjustment procedures will be described in chapter 4.

TABLE 3-1. COEFFICIENTS OF EMISSIONS MODELS
FOR PASSENGER CARS IN 1975 [LEE, 1983]

	CO	HC	NOx	CO2
S1	1.1655778E-01	5.3815991E-03	1.4689569E+00	2.6507999E-03
S2	-4.6298988E-03	-1.4550000E-04	7.0669018E-03	-3.5370002E-04
S3	6.9899994E-05	1.9999998E-06	1.6137001E-03	2.3400004E-05
B1	2.1578521E-01	8.0684014E-06	2.2840490E+00	1.0816000E-02
B2	-1.2577798E-02	-4.0020002E-04	-2.6279900E-02	-1.2250000E-03
B3	5.1477298E-02	9.0040010E-04	6.5590084E-02	-7.3540001E-04
B4	-2.3425999E-03	6.5000000E-05	5.3922199E-02	5.3939992E-04
B5	1.6780000E-04	6.6000002E-06	2.1289000E-03	4.4400003E-05
B6	-1.5755999E-03	-7.3569990E-04	-1.6557199E-01	-3.2972000E-03
B7	2.8229994E-04	8.9800000E-05	3.0232102E-02	5.2660005E-04
B8	1.2529999E-04	-3.0000001E-07	-9.0100002E-05	3.1199997E-06
B9	4.8500006E-05	-6.0000002E-07	-4.1270000E-04	-8.4000003E-06

Fuel Consumption Model for Passenger Cars

The fuel consumption model for passenger cars is expressed as a linear function of the amounts of HC, CO, and CO₂ emitted. The instantaneous fuel consumption model for 1975 is :

$$FF = 0.866 * HC + 0.429 * CO + 0.273 * CO_2$$

Truck Emissions and Fuel Consumption Models

Trucks are divided into single-unit and tractor semi-trailer types in the TEXAS model. Single-unit trucks are treated as light and tractor semi-trailers as heavy-duty trucks. Emissions and fuel consumption models for trucks are expressed as functions of engine performance (engine torque and engine speed).

Truck Emissions Models

Emissions models for gasoline trucks are (units = gram/sec):

$$\text{HC} = 6.526 (10^{-3}) + 1.088 (10^{-8}) |\text{TRQ}| \text{RPM} + 4.153 (10^{-11}) \text{TRQ}^4 - 5.46 (10^{-9}) |\text{TRQ}|^3$$

$$\text{CO} = 10.0^{**}(-2.636 + 3.190 (10^{-5}) \text{TRQ}^2 + 4.257 (10^{-2}) \sqrt{\text{RPM}} - 2.205 (10^{-6}) |\text{TRQ}| \text{RPM} + 1.659 (10^{-10}) \text{TRQ}^4)$$

$$\text{NO}_x = 10.0^{**}(-1.702 + 2.505 (10^{-2}) \sqrt{|\text{TRQ}|} - 8.991 (10^2) / \text{RPM} - 3.815 (10^{-10}) \text{TRQ}^4 + 8.504 (10^{-3}) |\text{TRQ}|)$$

Emissions models for diesel trucks (units = gram/sec) are:

$$\text{HC} = -1.183 (10^{-2}) + 3.459 (10^{-5}) \text{RPM} - 7.560 (10^{-6}) |\text{TRQ}| - 4.833 (10^{-9}) \text{RPM}^2$$

$$\text{CO} = 3.069 (10^{-2}) - 1.107 (10^{-3}) |\text{TRQ}| + 2.212 (10^{-7}) |\text{TRQ}| \text{RPM} + 1.103 (10^{-5}) \text{TRQ}^2$$

$$\text{NO}_x = 2.602 (10^{-2}) - 2.035 (10^{-4}) |\text{TRQ}| + 4.024 (10^{-7}) |\text{TRQ}| \text{RPM} + 6.591 (10^{-4}) \sqrt{|\text{TRQ}|}$$

Truck Fuel Consumption Models

The fuel consumption model for gasoline trucks is (units = gram/sec):

$$\text{FF}_g = -1.301 + 7.409 (10^{-6}) |\text{TRQ}| \text{RPM} + 7.105 (10^{-2}) \sqrt{\text{RPM}} + 3.555 (10^{-10}) \text{TRQ}^4$$

The fuel consumption model for diesel trucks is (units = gram/sec):

$$\text{FF}_d = -2.898 (10^{-2}) + 3.726 (10^{-3}) |\text{TRQ}| + 8.097 (10^{-6}) |\text{TRQ}| \text{RPM} + 8.467 (10^{-4}) (|\text{TRQ}| + \text{RPM}) - 1.180 (10^{-1}) \sqrt{|\text{TRQ}|}$$

Sensitivity Analysis of the Texas Model Emissions Processor

There are 12 classes of vehicles in the TEXAS model and they are presented in Table 3-2. Although emissions and fuel consumption for trucks are based upon engine performance, the emissions and fuel consumption for both trucks and passenger cars are relative to vehicle speed, acceleration, and deceleration. The relationships among emissions, velocity, and acceleration (deceleration) are shown in Figure 3-1 to Figure 3-9. To represent the sensitivity analysis for the TEXAS model emissions processor, the figures focus on carbon monoxide (CO).

TABLE 3-2. VEHICLE CLASS DATA

Class	Passenger cars				Truck							
					Single - Unit				Tractor Semi-Trailer			
					Gasoline		Diesel		Gasoline		Diesel	
	Sports	Compact	Medium	Large	PL*	FL**	PL	FL	PL	FL	PL	FL
	1	2	3	4	5	6	7	8	9	10	11	12

* PL - Partially-Loaded Truck
 ** FL - Fully-Loaded Truck

Vehicle classes 1 through 4 are described by the same equation because the independent variables for emissions and fuel consumption of passenger cars are speed and acceleration (deceleration). In the simulation processor of the TEXAS model, SIMPRO creates a file called POSDAT.DAT which includes vehicle position, speed, and acceleration (deceleration) data. The emissions processor EMPRO uses the instantaneous speed and acceleration (deceleration) of each vehicle to compute instantaneous vehicle emissions and fuel consumption. Figure 3-1 through Figure 3-9 indicate the emissions patterns are very smooth with no sharp changes for the emissions versus speed and acceleration (deceleration). This implies that the linear relation for speed and acceleration is suitable for estimating emissions values.

Figure 3-1 also shows the emissions for passenger cars are more sensitive to acceleration (deceleration) than to speed. However, emissions for trucks are more sensitive to speed than acceleration because when drivers want to change speed, they shift gears. The emissions rates decrease during the time interval of shifting the gear and increase when trucks move in the higher gear. Gasoline trucks and diesel trucks have different emissions patterns. It seems that gasoline trucks are more sensitive to speed than diesel trucks. When decelerating, the emissions rates for gasoline trucks are almost zero and are cleaner than diesel trucks.

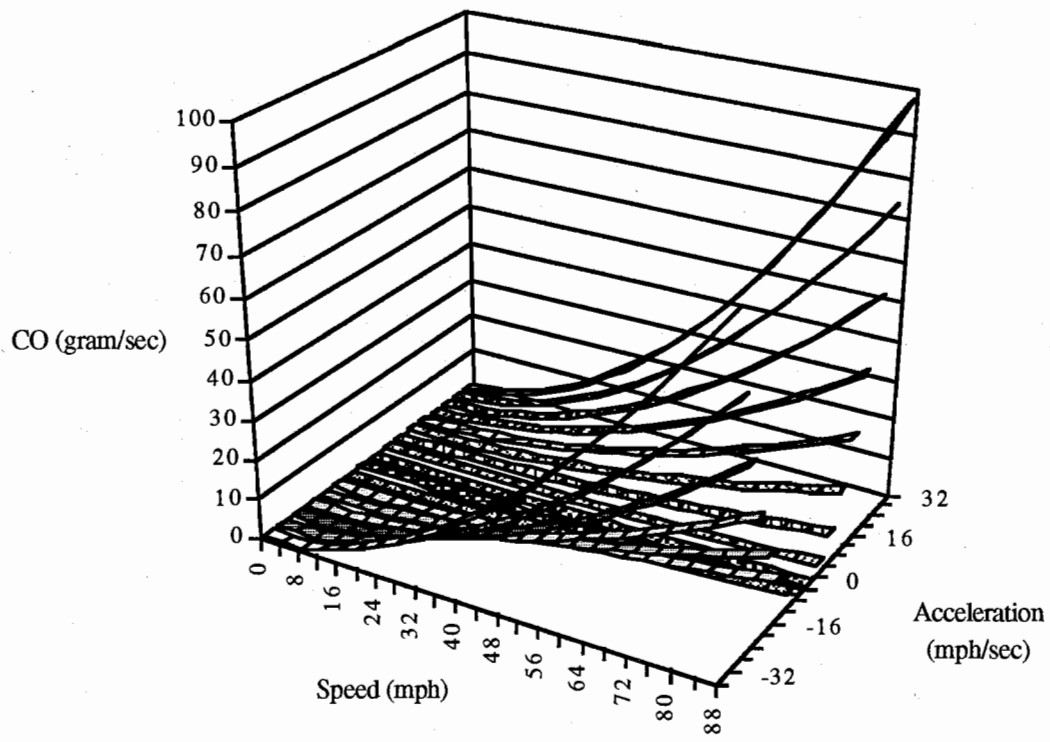

Figure 3-1. CO Emissions Rates for Vehicle Classes 1 to 4

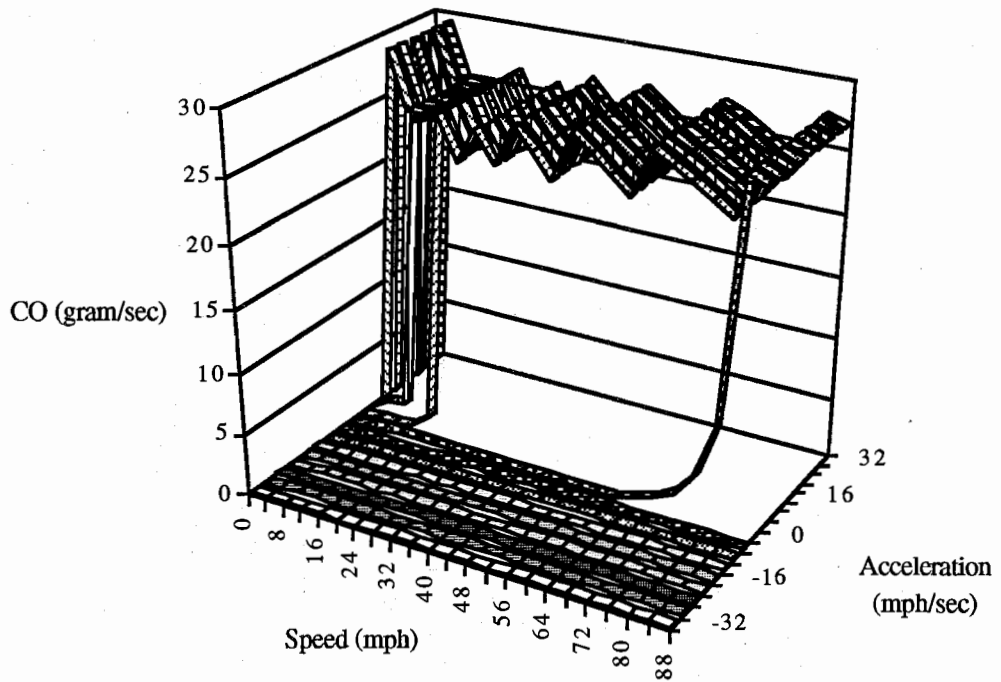

Figure 3-2. CO Emissions Rates for Vehicle Class 5

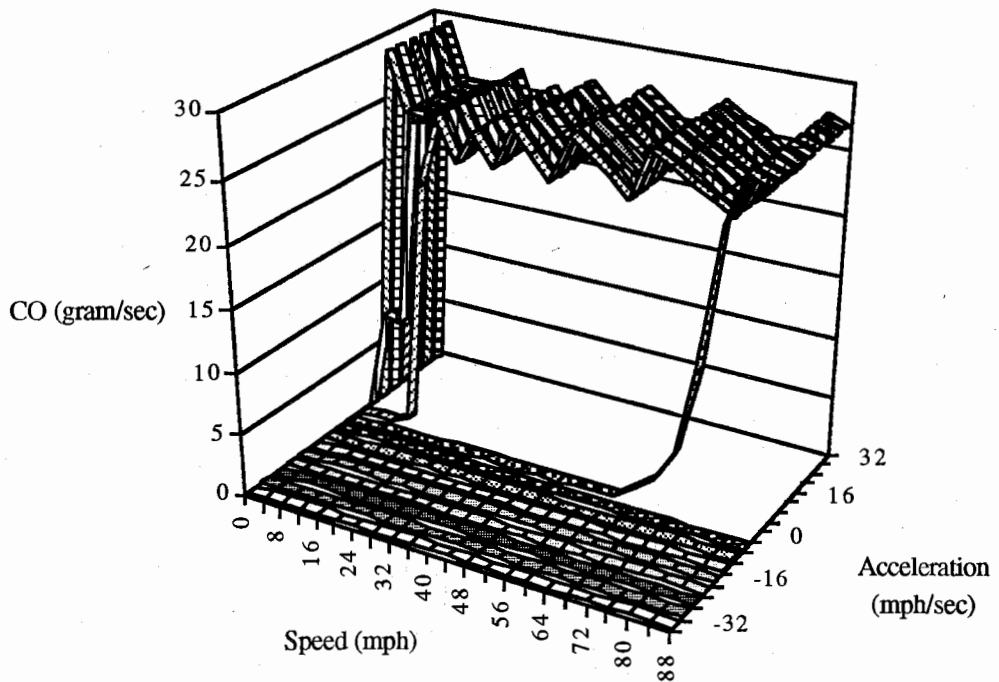

Figure 3-3. CO Emissions Rates for Vehicle Class 6

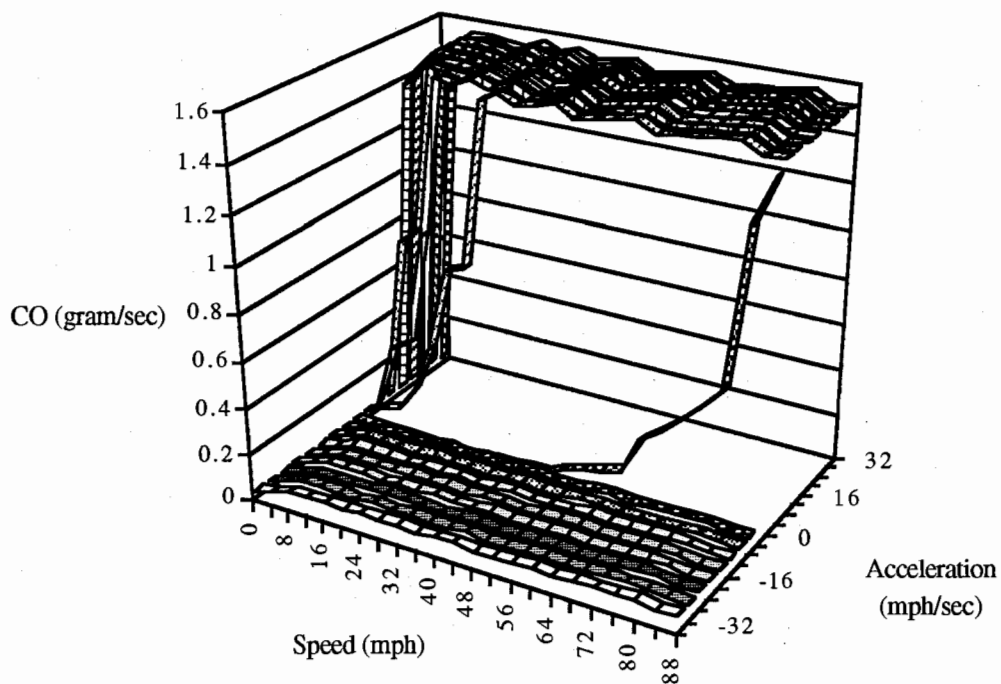

Figure 3-4. CO Emissions Rates for Vehicle Class 7

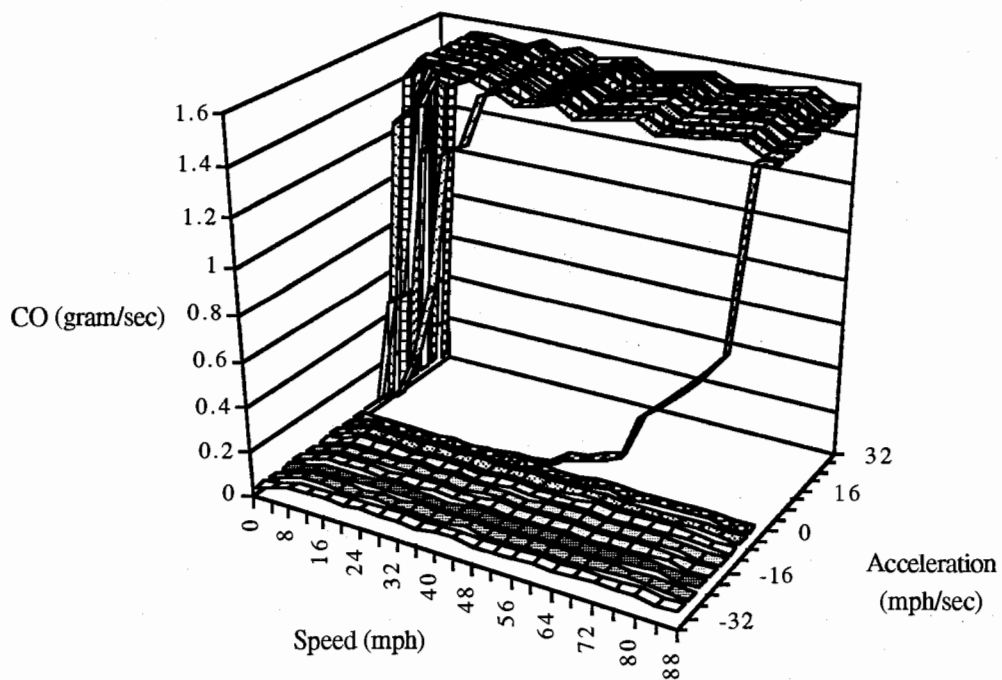

Figure 3-5. CO Emissions Rates for Vehicle Class 8

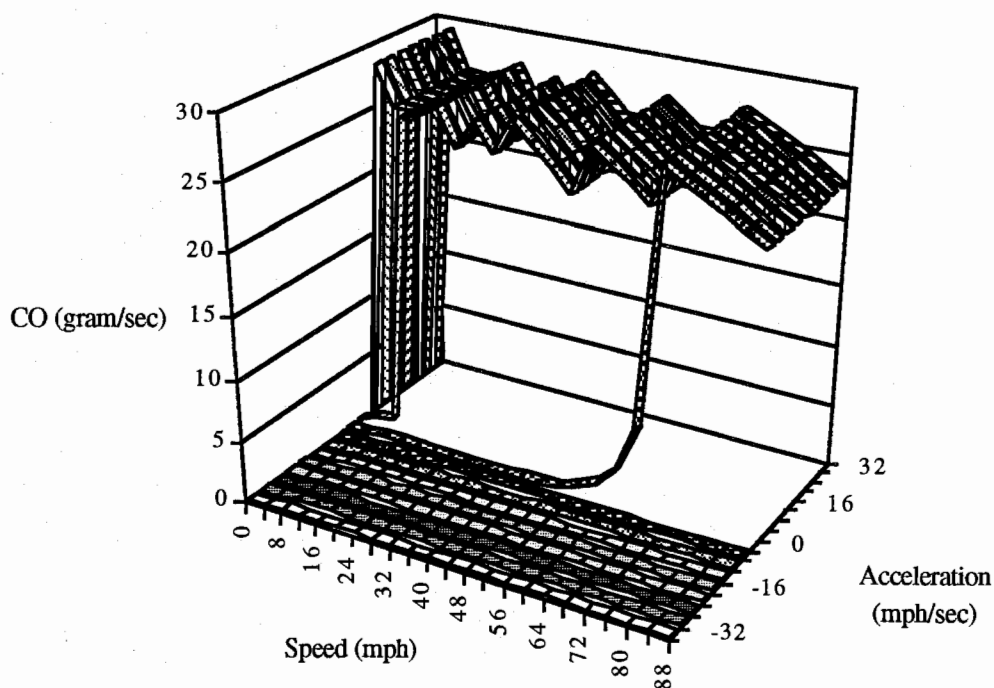

Figure 3-6. CO Emissions Rates for Vehicle Class 9

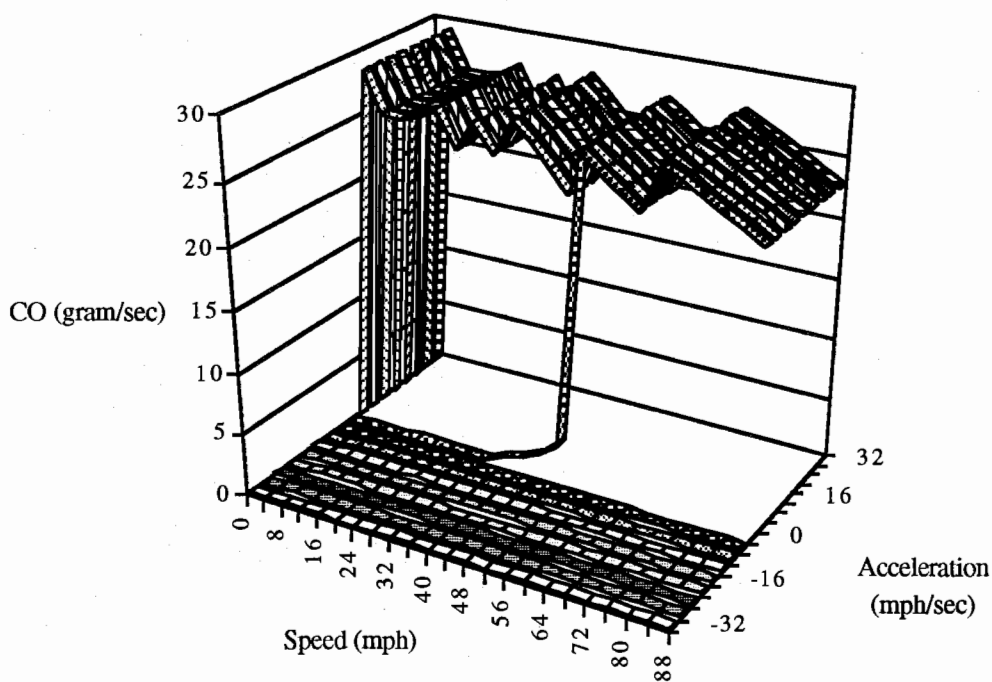

Figure 3-7. CO Emissions Rates for Vehicle Class 10

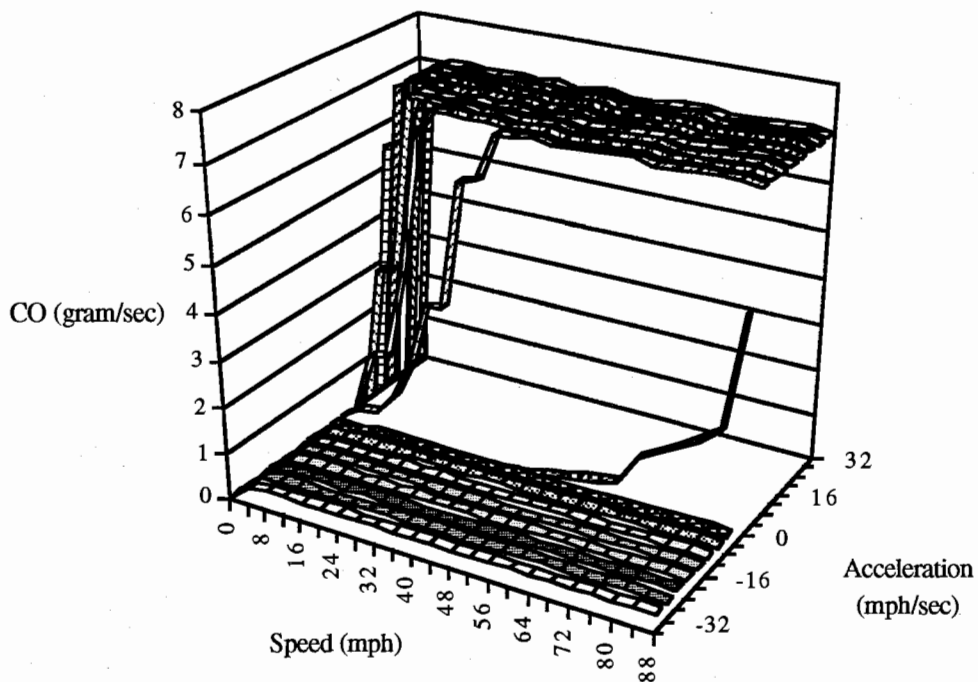

Figure 3-8. CO Emissions Rates for Vehicle Class 11

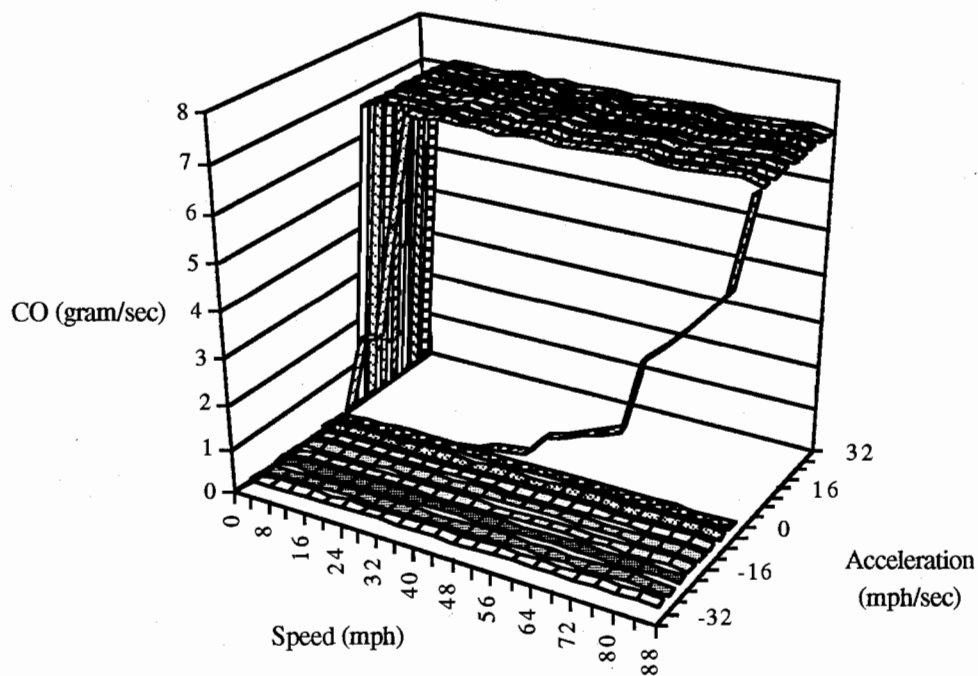

Figure 3-9. CO Emissions Rates for Vehicle Class 12

CHAPTER 4 MODIFICATION OF THE TEXAS MODEL EMISSIONS PROCESSOR

Modification Approach for Vehicle Emissions and Fuel Consumption Models

Since the vehicle emissions and fuel consumption models described in chapter 3 are based upon 1975 vehicle emissions rates, it is necessary to modify the models to permit simulation of the more current vehicle fleet. The initial vehicle emissions and fuel consumption models were developed by Hsin-Hsin Wu and Pramod Athalye in 1980, and Charlabos Simeonidis and Steve Beckel in 1981. They collected vehicle information based on vehicle types, modes, and manufactures and obtained vehicle emissions rates from EPA experimentation. Models developed to estimate carbon monoxide, hydrocarbons, oxides of nitrogen emissions, and fuel consumption were based upon vehicle speed, acceleration, and deceleration. Although those models can appropriately predict vehicle emissions and fuel consumption for 1975 vehicles, they cannot estimate vehicle emissions and fuel consumption for newer vehicles and cannot deal with a distribution of vehicle ages.

There are some possible modification alternatives. One possibility is to perform the same procedure which was done in 1980 and 1981; however, the time and cost associated with the procedure are prohibitive. Experimentation and verification of vehicle emissions rates are costly and difficult, it is not practical to do the procedure again. Due to successively more stringent federal emissions control requirements and fuel economy standards, prediction of vehicle emissions and fuel consumption should be associated with emissions control requirements, fuel economy standards and vehicle ages.

A modification alternative described in this paper is based on the original models and relative adjustment factors. Since the original models are based upon 1975 vehicle emissions rates, the adjustment factors for all vehicle types in 1975 are assumed 1.0. From 1976 to 1992, the adjustment factors of emissions are determined using federal emissions control requirements and vehicle age distribution with respect to 1975. Adjustment factors for fuel consumption are, likewise, determined using federal fuel economy standards and vehicle age distributions with respect to 1975. Therefore, vehicle emissions and fuel consumption in calendar year i can be predicted using the

1975 emissions and fuel consumption multiplied by the adjustment factors for year i. For instance, if carbon monoxide (CO) for passenger cars in 1975 is 15 grams per mile and the CO adjustment factor of passenger cars in 1992 is 0.44, then the CO for passenger cars in 1992 will be 15 grams per mile multiplied by 0.44 and is 6.6 grams per mile.

Federal Emissions Regulations and Fuel Economy Standards

Table 4-1 presents the federal emissions control requirements for automobiles, light-trucks, heavy-duty gasoline trucks, and heavy-duty diesel trucks and Table 4-2 contains the federal fuel economy standards. The assumption for the prediction procedure is that, once in service, vehicles continue to meet emissions requirements that were effective during the year they were built. While this is not likely true, it does lead to conservative emissions estimation. It is not problematic for relative estimates, that is, comparison of two or more TEXAS generated case studies.

Vehicle Age Distribution

Vehicle age distributions represent estimated fractions of each model year in service during any selected year. Generally, old vehicles produce more emissions and use more fuel. Vehicle age distributions provided by the U. S. Department of Transportation for years 1975 through 1990 are shown in Tables 4-3 and 4-4.

TABLE 4-1. FEDERAL EMISSIONS CONTROL REQUIREMENTS

Year	Automobiles (grams per mile)			Light trucks (grams per mile)			Heavy-Duty Gasoline Trucks (grams/brake horsepower hour)			(Heavy-Duty Diesel Trucks) (grams/brake horsepower hour)		
	HC	CO	NOx	HC	CO	NOx	HC	CO	NOx	HC	CO	NOx
1976	1.5	15	3.1	2	20	3.1	b*	40	b	b	40	b
1977	1.5	15	2	2	20	3.1	b	40	b	b	40	b
1978	1.5	15	2	2	20	3.1	b	40	b	b	40	b
1979	0.41	15	2	1.7	18	2.3	1.5	25	b	1.5	25	b
1980	0.41	7	2	1.7	18	2.3	1.5	25	b	1.5	25	b
1981	0.41	3.4	1	1.7	18	2.3	1.5	25	b	1.5	25	b
1982	0.41	3.4	1	1.7	18	2.3	1.5	25	b	1.5	25	b
1983	0.41	3.4	1	1.7	18	2.3	1.5	25	b	1.5	25	b
1984	0.41	3.4	1	0.8	10	2.3	1.3	15.5	10.7	1.3	15.5	10.7
1985	0.41	3.4	1	0.8	10	2.3	2.5	40	10.7	1.3	15.5	10.7
1986	0.41	3.4	1	0.8	10	2.3	2.5	40	10.7	1.3	15.5	10.7
1987	0.41	3.4	1	0.8	10	2.3	1.9	37.1	10.6	1.3	15.5	10.7
1988	0.41	3.4	1	0.8	10	1.2	1.9	37.1	10.6	1.3	15.5	10.7
1989	0.41	3.4	1	0.8	10	1.2	1.9	37.1	10.6	1.3	15.5	10.7
1990	0.41	3.4	1	0.8	10	1.2	1.9	37.1	6	1.3	15.5	6
1991	0.41	3.4	1	0.8	10	1.2	1.9	37.1	5	1.3	15.5	5
1992	0.41	3.4	1	0.8	10	1.2	1.9	37.1	5	1.3	15.5	5
1993	0.41	3.4	1	0.8	10	1.2	1.9	37.1	5	1.3	15.5	5
1994	0.25	3.4	0.4	0.25	3.4	1.2	1.9	37.1	5	1.3	15.5	5
1995-	0.25	3.4	0.4	0.25	3.4	0.4	1.9	37.1	5	1.3	15.5	5

TABLE 4-2. CORPORATE AVERAGE FUEL ECONOMY (CAFE) STANDARDS

Model Year	Automobiles (miles/gallon)	Light Trucks (miles/gallon)
1978	18	b
1979	19	17.2
1980	20	b
1981	22	b
1982	24	17.5
1983	26	19
1984	27	20
1985	27.5	19.5
1986	26	20
1987	26	20.5
1988	26	20.5
1989	26.5	20.5
1990	27.5	20
1991	27.5	20.2
1992	27.5	20.2

* b: no information for this year.

TABLE 4-3. PASSENGER CARS IN USE BY AGE (AS OF JULY 1)

(19~) Age	year															
	75	76	77	78	79	80	81	82	83	84	85	86	87	88	89	90
<1	4.9	6.6	7.2	7.2	7	5.6	4.9	4.1	4.6	6	5.8	6	5.9	5.6	5.3	4.9
1~2	10.3	7.9	9.6	10.1	10.9	9.9	8.3	7.7	6.8	6.9	9.1	9	8.9	8.5	8.4	7.9
2~3	11.9	10	7.5	9.2	9.9	10	9.7	8.3	7.6	6.7	6.7	8.8	8.7	8.8	8.4	8.3
3~4	10.6	11.4	9.6	7.1	8.2	9.5	9.7	9.4	8	7.3	6.4	6.5	8.4	8.5	8.5	8.3
4~5	9	10.1	10.9	9.2	6.2	8.5	9.2	9.5	9.2	7.8	7	6.2	6.3	8.3	8.3	8.4
5~6	8.8	8.4	9.6	10.3	7.9	6.4	8.3	9	9.2	8.8	7.4	6.7	5.9	6.1	8	8.1
6~7	8.8	8.1	7.9	8.9	7.9	8.1	6.1	7.9	8.6	8.8	8.4	7	6.4	5.6	5.9	7.7
7~8	7.9	8	7.5	7.1	6.7	8.8	7.6	5.8	7.5	8.2	8.3	7.9	6.6	6	5.4	5.6
8~9	6.4	7	7	6.6	4.6	7.2	8	7	5.4	7	7.6	7.7	7.4	6.1	5.6	5
9~10	6.1	5.5	5.9	5.9	4.4	5.4	6.4	7.1	6.3	4.8	6.3	6.9	7	6.8	5.6	5.1
10~11	5.1	5	4.4	4.8	4.5	4.7	4.6	5.6	6.2	5.4	4.2	5.5	6.2	6.3	6.1	5
11~12	3.4	4	3.9	3.5	3.4	3.9	4	4	4.8	5.3	4.5	3.5	4.6	5.3	5.5	5.4
12~13	2.3	2.6	3	3	2.9	3	3.2	3.4	3.3	4	4.3	3.6	2.9	3.8	4.5	4.7
13~14	1.5	1.8	2	2.3	2.8	2.3	2.5	2.6	2.8	2.8	3.2	3.4	2.9	2.3	3	3.7
14~15	0.7	1.1	1.3	1.5	2.3	1.9	1.8	2.1	2.2	2.3	2.2	2.6	2.6	2.2	1.8	2.4
15~16	0.5	0.5	0.8	1	1.8	1.4	1.6	1.5	1.7	1.8	1.9	1.7	2	2.1	1.7	9.5*
>=16	1.8	2	2.1	2.4	8.2	3.4	4.1	4.9	5.5	6.1	6.7	7	7.3	7.7	8	
Mean	6	6.2	6.2	6.3	6.4	6.6	6.9	7.2	7.4	7.5	7.6	7.6	7.6	7.6	7.6	7.8
Median	5.4	5.5	5.6	5.7	5.9	6	6	6.2	6.5	6.7	6.9	7	6.9	6.8	6.5	6.5

TABLE 4-4. TRUCKS IN USE BY AGE (AS OF JULY 1)

(19~) Age	year															
	75	76	77	78	79	80	81	82	83	84	85	86	87	88	89	90
<1	5.3	7.1	7.7	8.3	7.4	3.9	3.4	3.5	4.1	6.1	6.4	6.8	6.2	6.5	5.9	5.4
1~2	11	8.1	9.7	10.6	10.9	10.7	6.2	5.7	5.8	6.3	9	9.4	10	8.9	9.2	8.7
2~3	11.5	10.3	7.5	9	9.9	10.4	10.6	5.9	5.5	5.5	5.9	8.5	8.8	9.4	8.4	8.8
3~4	9.6	10.5	9.5	6.8	8.2	9.5	10.1	10.3	5.7	5.3	5.1	5.5	7.9	8.3	8.9	7.9
4~5	7	8.8	9.8	8.7	6.2	7.8	9.2	9.8	9.9	5.3	4.9	4.8	5.2	7.4	7.8	8.4
5~6	6.7	6.4	8.1	8.8	7.9	5.8	7.5	8.9	9.4	9.4	4.9	4.5	4.5	4.8	7	7.3
6~7	7.2	6.2	5.8	7.3	7.9	7.5	5.6	7.3	8.5	8.8	8.7	4.5	4.2	4.1	4.5	6.5
7~8	5.6	6.5	5.6	5.1	6.7	7.4	7.1	5.3	6.9	7.9	8.1	8	4.1	3.9	3.8	4.2
8~9	5.1	5.1	5.8	4.9	4.6	6.1	7	6.7	4.9	6.3	7.2	7.3	7.3	3.8	3.6	3.5
9~10	5.1	4.6	4.5	5.1	4.4	4.4	5.8	6.5	6.2	4.5	5.8	6.5	6.7	6.6	3.5	3.2
10~11	4.4	4.5	4	3.9	4.5	4.1	4	5.3	5.9	5.5	4	5	5.7	5.9	6	3.1
11~12	3.6	3.9	3.9	3.4	3.4	4.1	3.7	3.7	4.8	5.3	4.8	3.5	4.5	5.1	5.3	5.4
12~13	2.8	3.1	3.3	3.3	2.9	3	3.7	3.4	3.4	4.3	4.6	4.2	3	3.9	4.7	4.8
13~14	2.2	2.4	2.6	2.7	2.8	2.6	2.8	3.4	3.1	3	3.8	4	3.6	2.7	3.4	4
14~15	1.6	1.9	2	2.2	2.3	2.5	2.3	2.5	3.1	2.7	2.6	3.3	3.4	3.1	2.3	3
15~16	1.6	1.3	1.6	1.6	1.8	1.9	2.2	2.1	2.3	2.7	2.4	2.2	2.8	2.9	2.6	15.8
>=16	9.7	9.3	8.6	8.3	8.2	8.4	8.8	9.8	10.5	11.1	11.8	12	12.1	12.7	13.1	
Mean	6.9	7	6.9	6.9	6.9	7.1	7.5	7.8	8.1	8.2	8.1	8	8	7.9	7.9	8
Median	5.8	5.8	5.7	5.8	5.9	6.3	6.5	6.8	7.2	7.4	7.6	7.7	7.8	7.1	6.7	6.5

*This data represents the percentage of vehicle in use is greater than and equal to 15 years old in 1990.

Development of Adjustment Factors for Emissions and Fuel Consumption

Emissions Adjustment Factors for Passenger Cars

The vehicle emissions after 1975 can be predicted using following equation:

$$HC_i = HC_{1975} (EM_i)$$

HC_i : vehicle emission HC in year i

EM_i : vehicle emissions adjustment factor for year i

$$= \frac{\text{weighted federal fuel economy standard in year } i}{\text{weighted federal fuel economy standard in 1975}}$$

The weighted emissions control requirement is a cumulation of percentages of passenger cars in use by age multiplied by the emissions control requirement for that age. For example, Table 4-5 presents the weighted emissions control requirements in 1975, and Table 4-6 is the calculation for weighted emissions control requirements in 1990. Therefore, the 1975 vehicle emissions adjustment factor EM_{1975} for HC is $1.5/1.5 = 1$, for CO is $15/15 = 1$, and for NOx is $3.1/3.1 = 1$. The 1990 vehicle emissions adjustment factor

EM₁₉₉₀ for HC is 0.6901/1.5 = 0.4638, for CO is 6.5612/15 = 0.4374, and for NO_x is 1.4379/3.1 = 0.4638. Table 4-7 shows the final results of adjustment factors for each year.

TABLE 4-5. WEIGHTED EMISSIONS CONTROL REQUIREMENT FOR PASSENGER CARS IN 1975

Age	Model Year	% of Age	Emissions Control Requirement			Weighted Emissions Control Requirement		
			HC	CO	NOx	HC * % of age	CO * % of age	NOx * % of age
<1	1975	4.9	1.5	15	3.1	0.0735	0.7350	0.1519
1~2	1974	10.3	1.5	15	3.1	0.1545	1.5450	0.3193
2~3	1973	11.9	1.5	15	3.1	0.1785	1.7850	0.3689
3~4	1972	10.6	1.5	15	3.1	0.1590	1.5900	0.3286
4~5	1971	9	1.5	15	3.1	0.1350	1.3500	0.2790
5~6	1970	8.8	1.5	15	3.1	0.1320	1.3200	0.2728
6~7	1969	8.8	1.5	15	3.1	0.1320	1.3200	0.2728
7~8	1968	7.9	1.5	15	3.1	0.1185	1.1850	0.2449
8~9	1967	6.4	1.5	15	3.1	0.0960	0.9600	0.1984
9~10	1966	6.1	1.5	15	3.1	0.0915	0.9150	0.1891
10~11	1965	5.1	1.5	15	3.1	0.0765	0.7650	0.1581
11~12	1964	3.4	1.5	15	3.1	0.0510	0.5100	0.1054
12~13	1963	2.3	1.5	15	3.1	0.0345	0.3450	0.0713
13~14	1962	1.5	1.5	15	3.1	0.0225	0.2250	0.0465
14~15	1961	0.7	1.5	15	3.1	0.0105	0.1050	0.0217
15~16	1960	0.5	1.5	15	3.1	0.0075	0.0750	0.0155
>=16	1959	1.8	1.5	15	3.1	0.0270	0.2700	0.0558
		100						
Weighted Emissions Control Requirement (gram/mile)						1.5	15	3.1

**TABLE 4-6. WEIGHTED EMISSIONS CONTROL
REQUIREMENT FOR PASSENGER CARS IN 1990**

Age	Model Year	% of Age	Emissions Control Requirement			Weighted Emissions Control Requirement		
			HC	CO	NOx	HC * % of age	CO * % of age	NOx*% of age
< 1	1990	4.9	0.41	3.4	1	0.0201	0.1666	0.0490
1 ~ 2	1989	7.9	0.41	3.4	1	0.0324	0.2686	0.0790
2 ~ 3	1988	8.3	0.41	3.4	1	0.0340	0.2822	0.0830
3 ~ 4	1987	8.3	0.41	3.4	1	0.0340	0.2822	0.0830
4 ~ 5	1986	8.4	0.41	3.4	1	0.0344	0.2856	0.0840
5 ~ 6	1985	8.1	0.41	3.4	1	0.0332	0.2754	0.0810
6 ~ 7	1984	7.7	0.41	3.4	1	0.0316	0.2618	0.0770
7 ~ 8	1983	5.6	0.41	3.4	1	0.0230	0.1904	0.0560
8 ~ 9	1982	5	0.41	3.4	1	0.0205	0.1700	0.0500
9 ~ 10	1981	5.1	0.41	3.4	1	0.0209	0.1734	0.0510
10 ~ 11	1980	5	0.41	7	2	0.0205	0.3500	0.1000
11 ~ 12	1979	5.4	1.5	15	2	0.0810	0.8100	0.1080
12 ~ 13	1978	4.7	1.5	15	2	0.0705	0.7050	0.0940
13 ~ 14	1977	3.7	1.5	15	2	0.0555	0.5550	0.0740
14 ~ 15	1976	2.4	1.5	15	3.1	0.0360	0.3600	0.0744
>=15	1975	9.5	1.5	15	3.1	0.1425	1.4250	0.2945
		100						
Weighted Emissions Control Requirement (gram/mile)						0.6901	6.5612	1.4379

TABLE 4-7. EMISSIONS ADJUSTMENT FACTORS FOR PASSENGER CARS

Year	Weighted Emissions Control Requirements			Emissions Adjustment Factors		
	HC	CO	NOx	HC	CO	NOx
1975	1.5	15	3.1	1	1	1
1976	1.5	15	3.1	1	1	1
1977	1.5	15	3.0270	1	1	0.9765
1978	1.5	15	2.9128	1	1	0.9396
1979	1.5	15	2.8907	1	1	0.9325
1980	1.4390	14.5520	2.7150	0.9593	0.9701	0.8758
1981	1.3561	13.7676	2.5912	0.9041	0.9178	0.8359
1982	1.2794	12.9522	2.5912	0.8529	0.8635	0.8359
1983	1.2012	12.1110	2.3067	0.8008	0.8074	0.7441
1984	1.1218	11.2556	2.1655	0.7478	0.7504	0.6985
1985	1.0378	10.3480	2.0163	0.6919	0.6899	0.6504
1986	0.9528	9.4288	1.8683	0.6352	0.6286	0.6027
1987	0.8776	8.6140	1.7403	0.5851	0.5743	0.5614
1988	0.8079	7.8536	1.6251	0.5386	0.5236	0.5242
1989	0.7435	7.1512	1.5215	0.4957	0.4767	0.4908
1990	0.6901	6.5612	1.4379	0.4601	0.4374	0.4638

Fuel Consumption Adjustment Factors for Passenger Cars

The fuel consumption adjustment factor was developed using a similar procedure but substituting the federal fuel economy standards for emissions standards.

$$FF_i = FF_{1975} \left(\frac{1}{FE_i} \right)$$

FF_i : Fuel consumption in year i

FE_i : Fuel economy adjustment factor for year i
weighted federal fuel economy standard in year i
 = weighted federal fuel economy standard in 1975

The weighted federal fuel economy standard for automobiles is a cumulation of the percentages of passenger cars in use by age multiplied by the fuel economy standard for that year. As shown in Tables 4-8 and 4-9, the adjustment factor for fuel consumption $1/FE_{1975}$ is $18/18 = 1$ in 1975 and $1/FE_{1975}$ is $18/23.7055 = 0.7593$ in 1990. Table 4-10 shows the adjustment factors for each year.

TABLE 4-8. WEIGHTED FUEL ECONOMY STANDARDS FOR PASSENGER CARS IN 1975

Age	Model Year	% of Age	Fuel Economy Standards (miles per gallon)	Weighted Fuel Economy Standards Fuel Economy Standards * % of age
<1	1975	4.9	18	0.8820
1 ~ 2	1974	10.3	18	1.8540
2 ~ 3	1973	11.9	18	2.1420
3 ~ 4	1972	10.6	18	1.9080
4 ~ 5	1971	9.0	18	1.6200
5 ~ 6	1970	8.8	18	1.5840
6 ~ 7	1969	8.8	18	1.5840
7 ~ 8	1968	7.9	18	1.4220
8 ~ 9	1967	6.4	18	1.1520
9 ~ 10	1966	6.1	18	1.0980
10 ~ 11	1965	5.1	18	0.9180
11 ~ 12	1964	3.4	18	0.6120
12 ~ 13	1963	2.3	18	0.4140
13 ~ 14	1962	1.5	18	0.2700
14 ~ 15	1961	0.7	18	0.1260
15 ~ 16	1960	0.5	18	0.0900
>=16	1959	1.8	18	0.3240
		100		
Weighted Fuel Economy Standards (miles per gallon)				18

**TABLE 4-9. WEIGHTED FUEL ECONOMY
STANDARDS FOR PASSENGER CARS IN 1990**

Age	Model Year	% of Age	Fuel Economy Standards (miles per gallon)	Weighted Fuel Economy Standards Fuel Economy Standards * % of age
<1	1990	4.9	27.5	1.3475
1 ~ 2	1989	7.9	26.5	2.0935
2 ~ 3	1988	8.3	26	2.1580
3 ~ 4	1987	8.3	26	2.1580
4 ~ 5	1986	8.4	26	2.1840
5 ~ 6	1985	8.1	27.5	2.2275
6 ~ 7	1984	7.7	27	2.0790
7 ~ 8	1983	5.6	26	1.4560
8 ~ 9	1982	5.0	24	1.2000
9 ~ 10	1981	5.1	22	1.1220
10 ~ 11	1980	5.0	20	1.0000
11 ~ 12	1979	5.4	19	1.0260
12 ~ 13	1978	4.7	18	0.8460
13 ~ 14	1977	3.7	18	0.6660
14 ~ 15	1976	2.4	18	0.4320
>=15	1975	9.5	18	1.7100
		100		
Weighted Fuel Economy Standards (miles per gallon)				23.7055

**TABLE 4-10. FUEL CONSUMPTION ADJUSTMENT
FACTORS FOR PASSENGER CARS**

Year	Weighted Fuel Economy Standards	Fuel Consumption Adjustment Factors
1975	18	1
1976	18	1
1977	18	1
1978	18	1
1979	17.9980	1.0001
1980	18.2110	0.9884
1981	18.4590	0.9751
1982	18.7960	0.9577
1983	19.2780	0.9337
1984	20.0300	0.8987
1985	20.8020	0.8653
1986	21.5060	0.8370
1987	22.0865	0.8150
1988	22.6405	0.7950
1989	23.1760	0.7767
1990	23.7055	0.7593

Emissions Adjustment Factors for Trucks

There are different emissions control requirements for the three classes of trucks which include light trucks, heavy-duty gasoline, and heavy-duty diesel trucks. The adjustment procedure for trucks in each year is the same as for

passenger cars. Since we can only get the general truck age distribution, all the three classes of trucks are assumed to have the same age distribution. Tables 4-11 and 4-12 are the results for truck emissions adjustment factors in each year.

TABLE 4-11 EMISSIONS ADJUSTMENT
FACTORS FOR HEAVY-DUTY GASOLINE TRUCKS

Year	Weighted Emissions Control Requirements			Emissions Adjustment Factors		
	HC	CO	NOx	HC	CO	NOx
1975	1.5	40	10.7	1	1	1
1976	1.5	40	10.7	1	1	1
1977	1.5	40	10.7	1	1	1
1978	1.5	40	10.7	1	1	1
1979	1.5	38.8900	10.7	1	0.9723	1
1980	1.5	37.8500	10.7	1	0.9463	1
1981	1.5	36.9700	10.7	1	0.9243	1
1982	1.5	36.2300	10.7	1	0.9058	1
1983	1.5	35.3500	10.7	1	0.8838	1
1984	1.4878	33.7355	10.7	0.9919	0.8434	1
1985	1.5460	33.3700	10.7	1.0307	0.8343	1
1986	1.6450	33.8225	10.7	1.0967	0.8456	1
1987	1.6970	34.0897	10.6938	1.1313	0.8522	0.9994
1988	1.7238	34.2604	10.6846	1.1492	0.8565	0.9986
1989	1.7470	34.3935	10.6765	1.1647	0.8598	0.9978
1990	1.7672	34.6043	10.4208	1.1781	0.8651	0.9739

TABLE 4-12 EMISSIONS ADJUSTMENT
FACTORS FOR HEAVY-DUTY DIESEL TRUCKS

Year	Weighted Emissions Control Requirements			Emissions Adjustment Factors		
	HC	CO	NOx	HC	CO	NOx
1975	1.5	40	10.7	1	1	1
1976	1.5	40	10.7	1	1	1
1977	1.5	40	10.7	1	1	1
1978	1.5	40	10.7	1	1	1
1979	1.5	38.8900	10.7	1	0.9723	1
1980	1.5	37.8500	10.7	1	0.9463	1
1981	1.5	36.9700	10.7	1	0.9243	1
1982	1.5	36.2300	10.7	1	0.9058	1
1983	1.5	35.3500	10.7	1	0.8838	1
1984	1.4878	33.7355	10.7	0.9919	0.8434	1
1985	1.4692	31.8020	10.7	0.9795	0.7951	1
1986	1.4506	29.8535	10.7	0.9671	0.7463	1
1987	1.4342	28.1445	10.7	0.9561	0.7036	1
1988	1.4190	26.5975	10.7	0.9460	0.6649	1
1989	1.4056	25.2260	10.7	0.9371	0.6307	1
1990	1.3940	24.1050	10.4462	0.9293	0.6026	0.9763

Fuel Consumption Adjustment Factors for Trucks

Table 4-13 is the fuel consumption rate adjustment factors for trucks in each year. Again, the adjustment procedure for trucks in each year is the same as for passenger cars. Moreover, only light trucks have federal fuel economy standards, therefore, all three classes of trucks have the same fuel economy adjustment factors.

TABLE 4-13 FUEL CONSUMPTION ADJUSTMENT FACTORS FOR TRUCKS

Year	Weighted Fuel Economy Standards	Fuel Consumption Adjustment Factors
1975	17.2	1
1976	17.2	1
1977	17.2	1
1978	17.2	1
1979	17.2	1
1980	17.2	1
1981	17.2	1
1982	17.2277	0.9984
1983	17.2912	0.9947
1984	17.5007	0.9828
1985	17.7207	0.9706
1986	17.9580	0.9578
1987	18.2153	0.9443
1988	18.4682	0.9313
1989	18.6925	0.9202
1990	18.8606	0.9120

Summary

Emissions and fuel consumption adjustment factors have been developed incorporating vehicle age distribution. These procedures have been implemented within the EMPRO element of the TEXAS traffic simulation model.

CHAPTER 5 CONCLUSIONS AND RECOMMENDATIONS

The TEXAS model is a deterministic microscopic traffic simulation package which contains EMPRO an emissions and fuel consumption processor. The vehicle emissions and fuel consumption prediction processors described here produce reasonable results.

The original emissions and fuel consumption models properly estimate 1975 model year vehicle emissions and fuel consumption. Because of federal emissions control requirements and fuel economy standards change, the EMPRO models need to be updated.

Although the revised EMPRO emissions and fuel consumption models incorporating vehicle age adjustment factors produce appropriate vehicle emissions and fuel consumption estimates, there is still no prediction capability for future years. When federal emissions control requirements, fuel economy standards, and vehicle age distributions change, the adjustment factors for predicting emissions and fuel consumption need to be updated.

REFERENCES

1. Athalye, Pramod, Modeling Heavy-Duty Diesel Vehicles Emissions and Fuel Consumption, Master's Thesis, (Austin, Texas: Department of Civil Engineering, The University of Texas at Austin, August 1980).
2. Bullin, J. A., M. Hinz, S. C. Bower, Vehicle Emissions at Intersections, Report FHWA/TX-83/14+250-2F (College Station, Texas: Texas A&M University, 1983).
3. Compilation of Air Pollutant Emission Factors Volume II: Mobile Sources, PB91-167692 (Springfield, VA: U. S. Department of Commerce, 1991).
4. Davis, S. C. and P. S. Hu, Transportation Energy Data Book, 11th ed. (Oak Ridge: Oak Ridge National Lab, 1991).
5. Lee, Clyde E., Thomas W. Rioux, and Charlie R. Copeland, The TEXAS Model for Intersection Traffic-Development, Research Report No. 184-1 (Austin, Texas: Center for Highway Research, The University of Texas at Austin, December 1977).
6. Lee, Fong-Ping, Clyde E. Lee, Randy B. Machemehl, and Charlie R. Copeland, Simulation of Vehicle Emissions at Intersections, Research Report 250-1 (Austin, Texas: Center for Transportation Research, The University of Texas at Austin, August 1983).
7. Mcadams, H. T., Automobile Exhaust Emission Modal Analysis Model Extension and Refinement, Report EPA 460/3-74-024 (Buffalo, New York: Calspan Corporation, 1974).
8. MVMA Motor Vehicle Facts & Figures, 1975-1988, (Detroit, Michigan: Motor Vehicle Manufacturers Association of the United States, Inc.).
9. Sculley, Robert D., "Vehicle Emission Rate Analysis for Carbon Monoxide Hot Spot Modeling," JAPCA, vol. 39 (1989), pp. 1334-1343.

10. Simeonidis, Charalambos, Emissions and Fuel Consumption as Functions of Vehicle Speed and Acceleration, Master's Thesis, (Austin, Texas: Department of Civil Engineering, The University of Texas at Austin, December 1981).
11. Wu, Hsing Hsing, Modeling Heavy-Duty Gasoline Vehicle Emissions and Fuel Consumption, Master's Thesis, (Austin, Texas: Department of Civil Engineering, The University of Texas at Austin, August 1980).

APPENDIX A
DOCUMENTATION OF THE TEXAS MODEL EMISSIONS
PROCESSOR (EMPRO)

I. Data files used in EMPRO

There are two data files needed for users to run EMPRO on PC.

1. POSDAT

This data file is produced by SIMPRO processor, and it contains detailed vehicle position data for every vehicle per unit time. The EMPRO uses POSDAT to calculate instantaneous vehicle speed, acceleration, and deceleration, which are the most important variables to predict vehicle emissions and fuel consumption. The users are not allowed to modify any data in POSDAT.

The procedures to produce POSDAT file from the TEXAS model are demonstrated as follows:

> GDVDATA

Users need to define intersection geometry information and driver-vehicle data.

> DVPRO

DVPRO uses assigned characteristics of driver classes, vehicle classes, desired speed, desired outbound intersection leg, and lateral lane position on the inbound leg to generate attributes for each individual driver-vehicle unit. EMPRO uses information from SIMPRO about the instantaneous speed and acceleration (deceleration) of each vehicle to compute instantaneous vehicle emissions and fuel consumption along the vehicle paths

> SIMDATA

Users need to define "simulation parameter-option data" in SIMDATA processor. The users need to type in "FILE(8)=POL" to create POSDAT file and determine the simulation time.

>SIMPRO

SIMPRO integrates all the defined elements and computes deterministically the response of each driver-vehicle unit and simulates the traffic behavior of each unit according to momentary surrounding conditions. After running SIMPRO processor, the POSDAT will be created as one of the input data file for EMPRO processor.

2. EMSDAT

EMSDAT file is created by users. Table A-1 is the typical format of this data file. EMSDAT can be edited by PE, EDIT software on microcomputer and the users have to update or add new data in case of the new data are available in the future. Data contained in current EMSDAT are:

(1) Percentage of vehicle age distribution for passenger cars and trucks from 1975 to 1992 respectively. For example, the data coded in EMSDAT for 1975 auto age distribution are as follows:

19	xx	1	2	3	4	5	6	7	8	9	10	11	12	13	14	15	16
	17																
	75	4.9	10.3		11.9		10.6		9.0	8.8	8.8	7.9	6.4	6.1	5.1	3.4	2.3
		1.5	0.7	0.5	1.8												

This information reveals that among the total passenger cars used in 1975,
4.9% are one-year-old cars,
10.3% are two-years-old cars,
11.9% are three-years-old cars,

0.7% are fifteen-years-old cars,
0.5% are sixteen-years-old cars,
1.8% are more than sixteen-years-old cars.

The data for other years have the same meaning.

The newest available vehicle age distribution is for 1990. Therefore, in current EMSDAT file, the vehicle age distributions of 1991 and 1992 are assumed to be the same as those of 1990. Users have to update the data in EMSDAT file when the newer data are available.

(2) Federal emissions control requirements (1975 to 1992) of HC, CO, and NO_x for passenger cars, light-duty trucks, heavy-duty gasoline trucks, and heavy-duty diesel trucks.

(3) Corporate average fuel economy standards for passenger cars and light trucks. The standards for heavy-duty-trucks are assumed to be the same as the standards for light trucks due to no available standards for heavy-duty trucks.

II. The Procedure for Running the EMPRO Processor

Before running EMPRO, users must know the newest data of calendar year in the EMSDAT file.

The only command needed to run EMPRO is:

> EMPRO

After typing in this command, the screen will have the following messages:

Enter the newest data year in the EMSDAT.DAT file, For example, if the newest data

year is 1992 then key in 1992, if the newest is 1995, then key in 1995.

MAKE SURE you know the newest data year in your EMSDAT.DAT file and key in the number correctly.

An error in keying will cause an error in reading data from the EMSDAT.DAT file.

PLEASE ENTER NUMBER :

After keying in the number (the current newest data is 1992), the screen will show the following messages:

Emission and fuel consumption estimates depend upon current vehicle age

distributions.

Enter the four digit major model year number

(1975 to 1992) for the newest vehicles

composing part of age distribution of your area.

For example, if typical United States data are being simulated, then enter 1992

In current version default value is 1992

PLEASE ENTER NUMBER OR HIT RETURN FOR DEFAULT

The EMPRO will create vehicle emissions and fuel consumption results in files EMSTA.R?, EMSTAFIN.R?, and EMSTAFIN.AVE. Detailed outputs in these files are described in Appendix B.

Table A-1. EMSDAT.DAT data file

THIS DATA FILE CONTAINS: THE AGE DISTRIBUTION FOR AUTO & TRUCK,
 HC, CO, AND NOx EMISSION STANDARDS, AND
 FUEL ECONOMY STANDARDS

YEAR	AUTO AGE DISTRIBUTION (%)																
19xx	1	2	3	4	5	6	7	8	9	10	11	12	13	14	15	16	17
75	4.9	10.3	11.9	10.6	9.0	8.8	8.8	7.9	6.4	6.1	5.1	3.4	2.3	1.5	0.7	0.5	1.8
76	6.6	7.9	10.0	11.4	10.1	8.4	8.1	8.0	7.0	5.5	5.0	4.0	2.6	1.8	1.1	0.5	2.0
77	7.2	9.6	7.5	9.6	10.9	9.6	7.9	7.5	7.0	5.9	4.4	3.9	3.0	2.0	1.3	0.8	2.1
78	7.2	10.1	9.2	7.1	9.2	10.3	8.9	7.1	6.6	5.9	4.8	3.5	3.0	2.3	1.5	1.0	2.4
79	7.0	10.9	9.9	8.2	6.2	7.9	7.9	6.7	4.6	4.4	4.5	3.4	2.9	2.8	2.3	1.8	8.2
80	5.6	9.9	10.0	9.5	8.5	6.4	8.1	8.8	7.2	5.4	4.7	3.9	3.0	2.3	1.9	1.4	3.4
81	4.9	8.3	9.7	9.7	9.2	8.3	6.1	7.6	8.0	6.4	4.6	4.0	3.2	2.5	1.8	1.6	4.1
82	4.1	7.7	8.3	9.4	9.5	9.0	7.9	5.8	7.0	7.1	5.6	4.0	3.4	2.6	2.1	1.5	4.9
83	4.6	6.8	7.6	8.0	9.2	9.2	8.6	7.5	5.4	6.3	6.2	4.8	3.3	2.8	2.2	1.7	5.5
84	6.0	6.9	6.7	7.3	7.8	8.8	8.8	8.2	7.0	4.8	5.4	5.3	4.0	2.8	2.3	1.8	6.1
85	5.8	9.1	6.7	6.4	7.0	7.4	8.4	8.3	7.6	6.3	4.2	4.5	4.3	3.2	2.2	1.9	6.7
86	6.0	9.0	8.8	6.5	6.2	6.7	7.0	7.9	7.7	6.9	5.5	3.5	3.6	3.4	2.6	1.7	7.0
87	5.9	8.9	8.7	8.4	6.3	5.9	6.4	6.6	7.4	7.0	6.2	4.6	2.9	2.9	2.6	2.0	7.3
88	5.6	8.5	8.8	8.5	8.3	6.1	5.6	6.0	6.1	6.8	6.3	5.3	3.8	2.3	2.2	2.1	7.7
89	5.3	8.4	8.4	8.5	8.3	8.0	5.9	5.4	5.6	5.6	6.1	5.5	4.5	3.0	1.8	1.7	8.0
90	4.9	7.9	8.3	8.3	8.4	8.1	7.7	5.6	5.0	5.1	5.0	5.4	4.7	3.7	2.4	1.7	7.8
91	4.9	7.9	8.3	8.3	8.4	8.1	7.7	5.6	5.0	5.1	5.0	5.4	4.7	3.7	2.4	1.7	7.8
92	4.9	7.9	8.3	8.3	8.4	8.1	7.7	5.6	5.0	5.1	5.0	5.4	4.7	3.7	2.4	1.7	7.8
YEAR	TRUCK AGE DISTRIBUTION (%)																
19xx	1	2	3	4	5	6	7	8	9	10	11	12	13	14	15	16	17
75	5.3	11.0	11.5	9.6	7.0	6.7	7.2	5.6	5.1	5.1	4.4	3.6	2.8	2.2	1.6	1.6	9.7
76	7.1	8.1	10.3	10.5	8.8	6.4	6.2	6.5	5.1	4.6	4.5	3.9	3.1	2.4	1.9	1.3	9.3
77	7.7	9.7	7.5	9.5	9.8	8.1	5.8	5.6	5.8	4.5	4.0	3.9	3.3	2.6	2.0	1.6	8.6
78	8.3	10.6	9.0	6.8	8.7	8.8	7.3	5.1	4.9	5.1	3.9	3.4	3.3	2.7	2.2	1.6	8.3
79	7.4	10.9	9.9	8.2	6.2	7.9	7.9	6.7	4.6	4.4	4.5	3.4	2.9	2.8	2.3	1.8	8.2
80	3.9	10.7	10.4	9.5	7.8	5.8	7.5	7.4	6.1	4.4	4.1	4.1	3.0	2.6	2.5	1.9	8.4
81	3.4	6.2	10.6	10.1	9.2	7.5	5.6	7.1	7.0	5.8	4.0	3.7	3.7	2.8	2.3	2.2	8.8
82	3.5	5.7	5.9	10.3	9.8	8.9	7.3	5.3	6.7	6.5	5.3	3.7	3.4	3.4	2.5	2.1	9.8
83	4.1	5.8	5.5	5.7	9.9	9.4	8.5	6.9	4.9	6.2	5.9	4.8	3.4	3.1	3.1	2.3	10.5
84	6.1	6.3	5.5	5.3	5.3	9.4	8.8	7.9	6.3	4.5	5.5	5.3	4.3	3.0	2.7	2.7	11.1
85	6.4	9.0	5.9	5.1	4.9	4.9	8.7	8.1	7.2	5.8	4.0	4.8	4.6	3.8	2.6	2.4	11.8
86	6.8	9.4	8.5	5.5	4.8	4.5	4.5	8.0	7.3	6.5	5.0	3.5	4.2	4.0	3.3	2.2	12.0
87	6.2	10.0	8.8	7.9	5.2	4.5	4.2	4.1	7.3	6.7	5.7	4.5	3.0	3.6	3.4	2.8	12.1
88	6.5	8.9	9.4	8.3	7.4	4.8	4.1	3.9	3.8	6.6	5.9	5.1	3.9	2.7	3.1	2.9	12.7
89	5.9	9.2	8.4	8.9	7.8	7.0	4.5	3.8	3.6	3.5	6.0	5.3	4.7	3.4	2.3	2.6	13.1
90	5.4	8.7	8.8	7.9	8.4	7.3	6.5	4.2	3.5	3.2	3.1	5.4	4.8	4.0	3.0	2.6	13.2
91	5.4	8.7	8.8	7.9	8.4	7.3	6.5	4.2	3.5	3.2	3.1	5.4	4.8	4.0	3.0	2.6	13.2
92	5.4	8.7	8.8	7.9	8.4	7.3	6.5	4.2	3.5	3.2	3.1	5.4	4.8	4.0	3.0	2.6	13.2

Table A-1. EMSDAT.DAT data file
(continue)

AUTO EMISSION STANDARDS (gram per horsepower hour)

	MODEL YEAR (19xx)																	
	75	76	77	78	79	80	81	82	83	84	85	86	87	88	89	90	91	92
HC	1.5	1.5	1.5	1.5	1.5	0.41	0.41	0.41	0.41	0.41	0.41	0.41	0.41	0.41	0.41	0.41	0.41	0.41
CO	15	15	15	15	15	7	3.4	3.4	3.4	3.4	3.4	3.4	3.4	3.4	3.4	3.4	3.4	3.4
NO	3.1	3.1	2	2	2	2	1	1	1	1	1	1	1	1	1	1	1	1

LIGHT TRUCK EMISSION STANDARDS (gram per horsepower hour)

	MODEL YEAR (19xx)																	
	75	76	77	78	79	80	81	82	83	84	85	86	87	88	89	90	91	92
HC	2	2	2	2	1.7	1.7	1.7	1.7	1.7	0.8	0.8	0.8	0.8	0.8	0.8	0.8	0.8	0.8
CO	20	20	20	20	18	18	18	18	18	10	10	10	10	10	10	10	10	10
NO	3.1	3.1	3.1	3.1	2.3	2.3	2.3	2.3	2.3	2.3	2.3	2.3	2.3	1.2	1.2	1.2	1.2	1.2

HEAVY-DUTY GASOLINE TRUCK EMISSION STANDARDS (gram per horsepower hour)

	MODEL YEAR (19xx)																	
	75	76	77	78	79	80	81	82	83	84	85	86	87	88	89	90	91	92
HC	1.5	1.5	1.5	1.5	1.5	1.5	1.5	1.5	1.5	1.3	2.5	2.5	1.9	1.9	1.9	1.9	1.9	1.9
CO	40	40	40	40	25	25	25	25	25	15.5	40	40	37.1	37.1	37.1	37.1	37.1	37.1
NO	10.7	10.7	10.7	10.7	10.7	10.7	10.7	10.7	10.7	10.7	10.7	10.7	10.6	10.6	10.6	6	5	5

HEAVY-DUTY DIESEL TRUCK EMISSION STANDARDS (gram per horsepower hour)

	MODEL YEAR (19xx)																	
	75	76	77	78	79	80	81	82	83	84	85	86	87	88	89	90	91	92
HC	1.5	1.5	1.5	1.5	1.5	1.5	1.5	1.5	1.5	1.3	1.3	1.3	1.3	1.3	1.3	1.3	1.3	1.3
CO	40	40	40	40	25	25	25	25	25	15.5	15.5	15.5	15.5	15.5	15.5	15.5	15.5	15.5
NO	10.7	10.7	10.7	10.7	10.7	10.7	10.7	10.7	10.7	10.7	10.7	10.7	10.7	10.7	10.7	6	5	5

AUTO FUEL ECONOMY STANDARDS (MPG)

	MODEL YEAR (19xx)																	
	75	76	77	78	79	80	81	82	83	84	85	86	87	88	89	90	91	92
FUEL	18	18	18	18	19	20	22	24	26	27	27.5	26	26	26	26.5	27.5	27.5	27.5

LIGHT TRUCK FUEL ECONOMY STANDARDS (MPG)

	MODEL YEAR (19xx)																	
	75	76	77	78	79	80	81	82	83	84	85	86	87	88	89	90	91	92
FUEL	17.2	17.2	17.2	17.2	17.2	17.2	17.2	17.5	19	20	19.5	20	20.5	20.5	20.5	20	20.2	20.2

APPENDIX B EMPRO, EMISSIONS PROCESSOR, OUTPUT

After running the EMPRO.EXE execution file, information shown on computer screen is:

Emissions Processor Listing is on EMLIST.R*.

Emissions Processor Error Listing is on or EMERR.R*.

Emissions Statistics Detail Processes are now on or EMSTA.R*.

Emissions Statistics Final Results are now on EMSTAFIN.R*.

Emissions Statistics Average Final Results are now on EMSTAFIN.AVE .

Due to simulation randomness of the TEXAS model, EMPRO has also been updated to permit replicates. Now, EMPRO can run at most ten replicates and produce ten EMSTA.* files from EMSTA.R1 through EMSAT.R10 and ten EMSTAFIN.* files from EMSTAFIN.R1 through EMSTAFIN.R10. The average results of EMSTAFIN.* files are in file EMSTAFIN.AVE.

Users can choose EMSTAFIN.R* to get emissions and fuel consumption results for the last simulation stage, or choose EMSTA.DAT to trace more detailed results for each section on intersection approaches and lanes for 5 minute simulation intervals (300 seconds).

Outputs in EMSTA.* include:

Emissions (CO, HC and NO) and fuel consumption (FF) results for each bucket on each lane.

Total emissions and fuel consumption results on each lane.

Emissions and fuel consumption results for each bucket on each approach.

Total emissions and fuel consumption results on each approach.

Emissions and fuel consumption results for the first bucket on each lane.

Emissions and fuel consumption results for the first bucket at the intersection.

Total emissions and fuel consumption results for the intersection.

Emissions and fuel consumption results for each vehicle class.

Outputs in EMSTAFIN.R* include:

Total emissions and fuel consumption results on each approach.

Emissions and fuel consumption results for the first bucket on each approach.

Total emissions and fuel consumption results for the intersection.

Emissions and fuel consumption results for each vehicle class.

Output in EMSTAFIN.AVE includes:

Total emissions and fuel consumption results for the intersection.

Emissions and fuel consumption results for each vehicle class.